

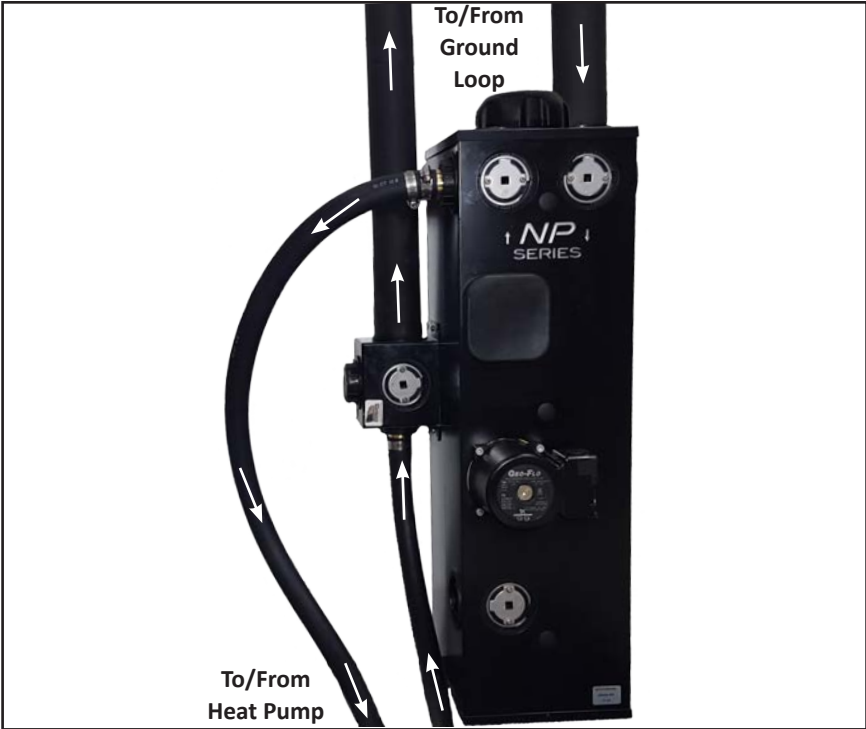

www.geo-flo.com

Engineered Solutions  
Making Geothermal Easier

# Installation, Operating, and Maintenance Manual



Part # 3761  
Rev. 03OCT2016

## NP and NP Plus Non-Pressurized Flow Centers

Geo-Flo Products Corporation  
905 Williams Park Drive  
Bedford, Indiana 47421, U.S.A.  
3761-10-03-16

Main Number: 812-275-8513  
Toll Free: 800-784-8069  
Fax: 888-477-8829

# Table of Contents

General Description . . . . .	1
Available Flow Center Models . . . . .	2
Flow Center Pump Sizing. . . . .	3
Installation . . . . .	4
Flushing and Purging . . . . .	7
Pump High Voltage Wiring . . . . .	.14
Optional Pressure Relief Piping . . . . .	.15
Start-up . . . . .	.16
Maintenance. . . . .	.18
Troubleshooting . . . . .	.21

## NOTES:

This guide provides the installer with instructions specific to NP and NP Plus Flow Centers. Please refer to your heat pump manufacturer’s instructions or IGSHPA guidelines for additional detailed flushing, purging, and installation information. Please review the entire IOM document before proceeding with the installation.

Geo-Flo Products Corporation is continually working to improve its products. As a result, the design and specifications of products in this catalog may change without notice and may not be as described herein. For the most up-to-date information, please visit our website, or contact our customer service department. Statements and other information contained in this document are not express warranties and do not form the basis of any bargain between the parties, but are merely Geo-Flo’s opinion or commendation of its products.

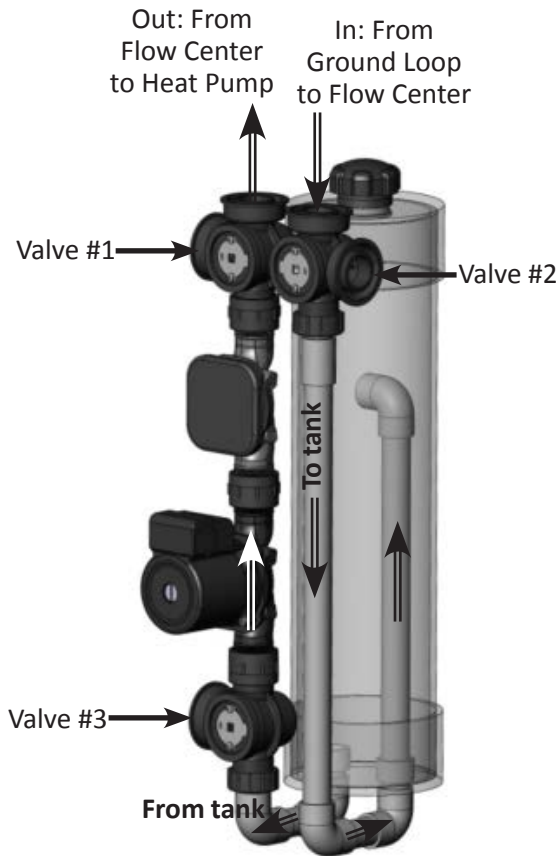

Figure 1: Generalized fluid flow (components inside cabinet)

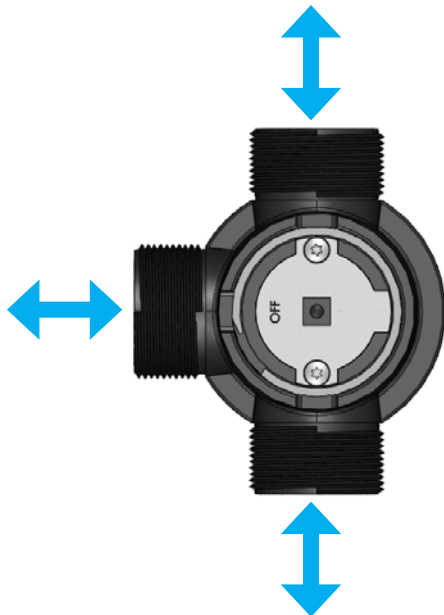

Figure 2: Potential flow paths through 3-way valve

## General Description

The NP Series is a family of non-pressurized flow centers used for closed-loop geothermal (ground source) heat pump systems. The NP Series flow centers use a water column to provide the necessary suction head for the circulator pump, and to ensure a flooded pump volute. Each NP Series flow center consists of a fluid reservoir (tank), flush and service valves, and one or more pumps housed in a foam-insulated cabinet. The flow center includes a sealing cap to ensure a closed system and provide pressure and vacuum relief to prevent the reservoir from being over-pressurized or dropping below atmospheric pressure. The NP Series is manufactured with single speed, three speed, and variable speed pumps to provide a variety of options to the contractor and system designer.

Figure 1 shows the fluid flow to and from the NP Series flow center. The valves will be referred to as valve #1, #2, and #3 as labeled in Figure 1 for the purpose of explanation throughout this document. The fluid is pumped from the flow center's tank on the left side, travels up through the bottom valve (valve #3), through the pump(s), and out the top left valve (valve #1). The fluid returns from the ground loop through the top right valve (valve #2) and is directed to the tank where any air present in the fluid is released. All valves included in the flow center are identical 3-way, 4-position valves. This allows the fluid flow to be stopped or directed as needed for choice of plumbing, flushing/purging, and service. Figure 2 shows the possible flow directions through each valve. The fluid has three potential paths through the valve as indicated by the three threaded ports. The valve spool can be rotated to 4 different positions with a 3/8" square drive tool such as a ratchet wrench. The flow directions on the spool are indicated by the "T" shape on the stainless drive plate. The drive plate is marked with "OFF" which indicates the direction that fluid will not flow. For example, in Figure 2 the OFF position is oriented to the left indicating that flow will not go through this port, and will instead pass straight through the valve. If OFF were turned to the 12 o'clock position, the flow would be directed between the bottom and left side ports.

**IMPORTANT: NP Series flow centers require Flo-Link double O-ring adapter fittings. The threads are for holding the adapter in place only, and will not seal, as they are straight mechanical threads.**

## Available Models

Non-pressurized flow centers are installed in a number of different configurations with regard to piping connections, as well as header location. The original NP Series flow center, introduced by Geo-Flo in 2013, included many different options for piping. However, due to the variation in installations, customers asked for easier to install options. In 2016, Geo-Flo introduced the NP Plus, which includes all of the typical components needed for outside header installations, while keeping the the original NP Series in the product line for internal header options. Below is a description of the two types of NP Series flow centers, as well as pictures illustrating typical connections.

- **NP Flow Center:** The NP Flow Center (shown on the right) is the original product. With the introduction of the NP Plus (see below), the NP Flow Center is now better suited to installations with inside headers (see Figure 6). HDPE fusion, PVC glue, threaded adapters, and other types of Flo-Link fittings are available to connect the flow center to the header piping and heat pump. **The NP Flow Center does not ship with any fittings.**
- **NP Plus Flow Center:** The NP Plus (see below) includes an external 3-way flushing/purging valve, a set of ground loop adapters, and a larger cap than the NP Flow Center\*. The NP Plus is designed for ease of installation for a ground loop application with an external header. All of the components needed for connecting to the ground loop are included. A hose kit or a set of Flo-Link double O-ring adapters is all that is required for connection to the heat pump.



NP Flow Center

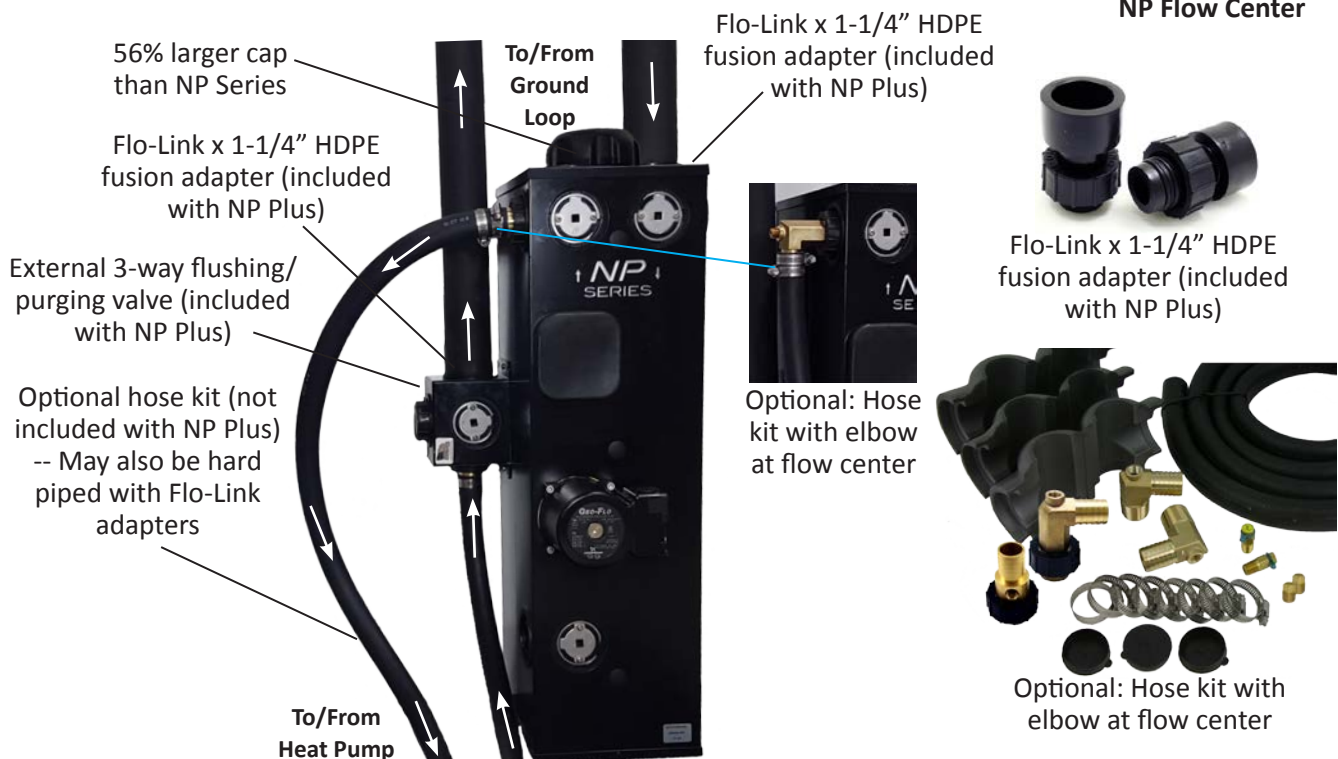

NP Plus Flow Center

\*To be updated to larger cap late 2016/early 2017 time frame.

## Flow Center sizing:

### Performance curves

The specific NP Series flow center should be selected based on the system pressure drop (including the geothermal heat pump, ground loop piping, and interior piping) and desired system efficiency. Calculators to assist with pressure drop determination and pump selection are available at [www.geo-flo.com](http://www.geo-flo.com). NP 1 and NP 2 are standard efficiency models while NP V and NP V2 are high efficiency models. The flow center selected should provide at least the minimum amount of flow recommended by the heat pump manufacturer for the heat pump being used.

Grundfos Pump Performance Curves (Single Pump)

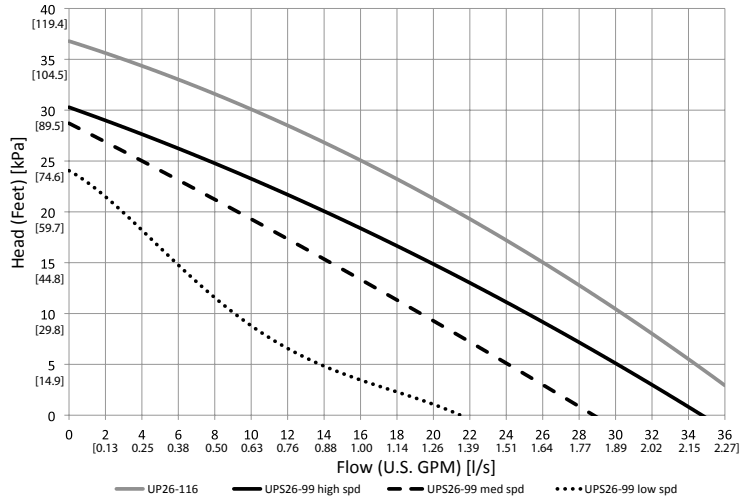

Grundfos Pump Performance Curves (Two Pumps)

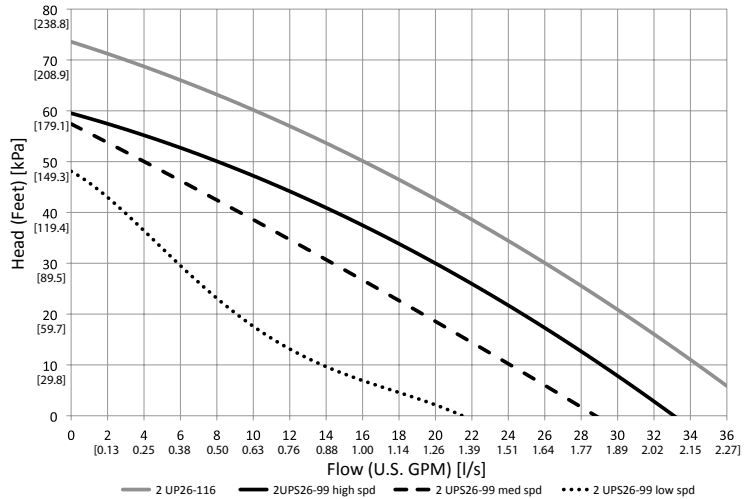

Grundfos Magna GEO 32-140 Performance Curves (Single Pump)

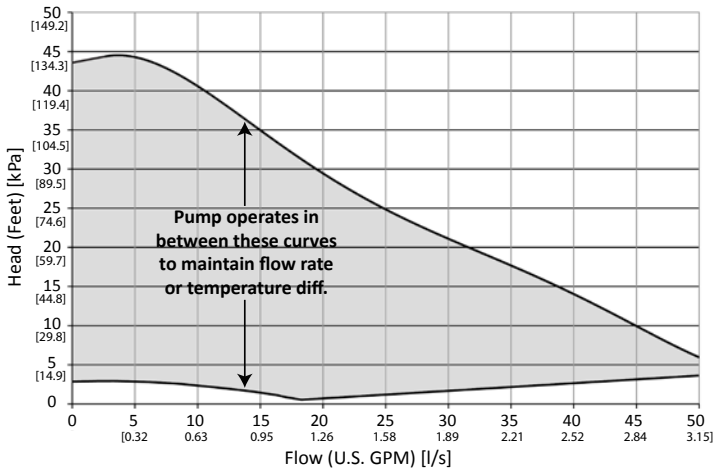

Grundfos Magna GEO 32-140 and UPS26-99 (pumps in series)

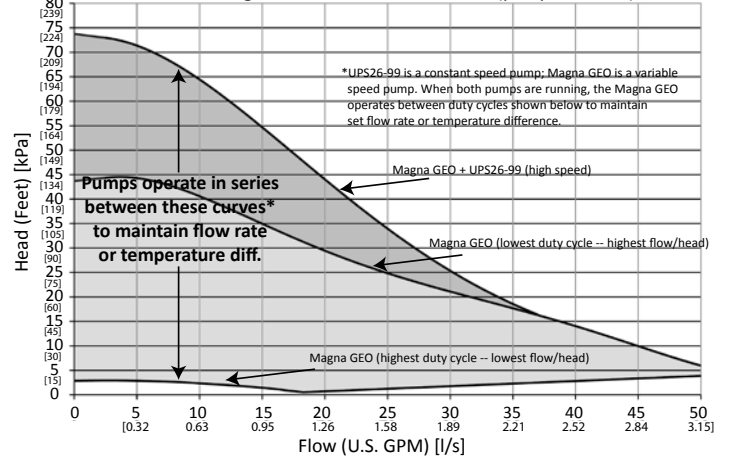

## Installation

### Mounting the unit

The NP Series flow center must be mounted on a level surface near the ground source heat pump. The unit can be placed on the floor or on an isolation pad such as a small piece of expanded polystyrene (blue board insulation). A 5/16" lag screw is provided to allow the unit to be secured to a wall as an anti-tip feature. If this method is desired, the screw should be driven into a wall stud approximately 24" above the mounting surface so that a 1/16" gap remains between the wall and base of the screw head (Figure 3). The NP flow center can then be slid into place utilizing the key hole in the back of the unit.

### Plumbing Options

The NP Series flow center can be plumbed with a wide variety of materials including HDPE, PVC, copper, PEX, and flexible hose to provide unlimited options to the installer. The flow directions to and from the flow center are shown in Figure 4. The installer can choose to direct the fluid flow through the top or sides of the flow center depending on how the interior piping is installed. The flow direction is chosen by turning each of the 3-way valves with a 3/8" square drive on a ratchet wrench so that the fluid is directed in the desired way. Flow direction through the 3-way valve is described in the General Description section of this document (page 1).

Figure 5 shows a standard piping configuration utilizing HDPE and a flexible hose transition to the heat pump. This configuration allows simple installation, and vibration isolation between the heat pump and flow center. The external insulated 3-way valve (included with NP Plus) allows the heat pump to be isolated from the loop, and allows the loop to be flushed independent of the heat pump. This can be useful when the flow center is installed prior to the heat pump. Figure 6 shows a piping configuration utilizing PVC pipe and internal headers. The optional bypass valve(s) allow the ground loop to be isolated from the heat pump. In addition, they allow the ground loop to be flushed independent of the heat pump. Note that the options shown are valid whether inside or outside headers are used.

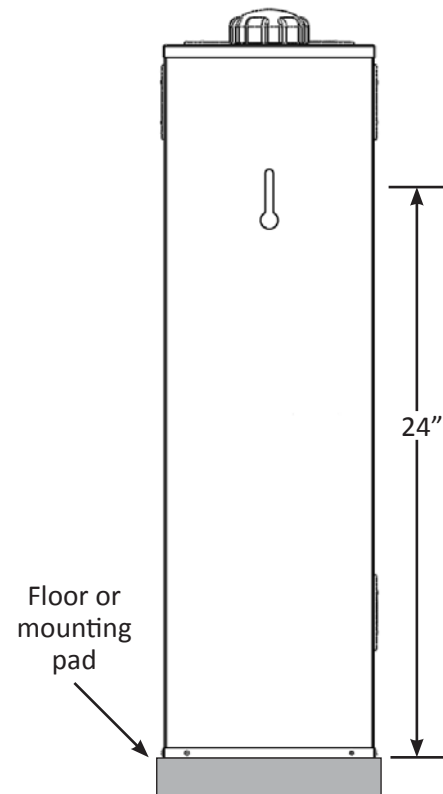

Figure 3: Mounting flow center

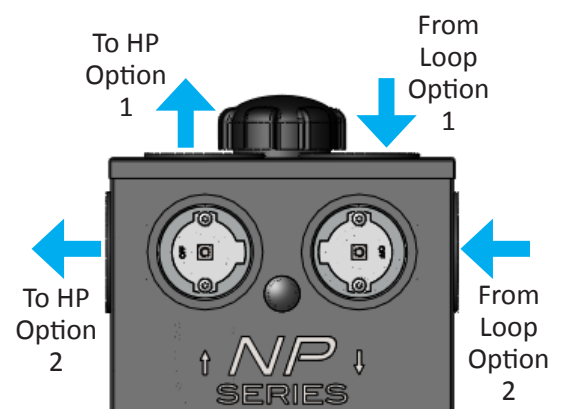

Figure 4: Fluid flow direction options

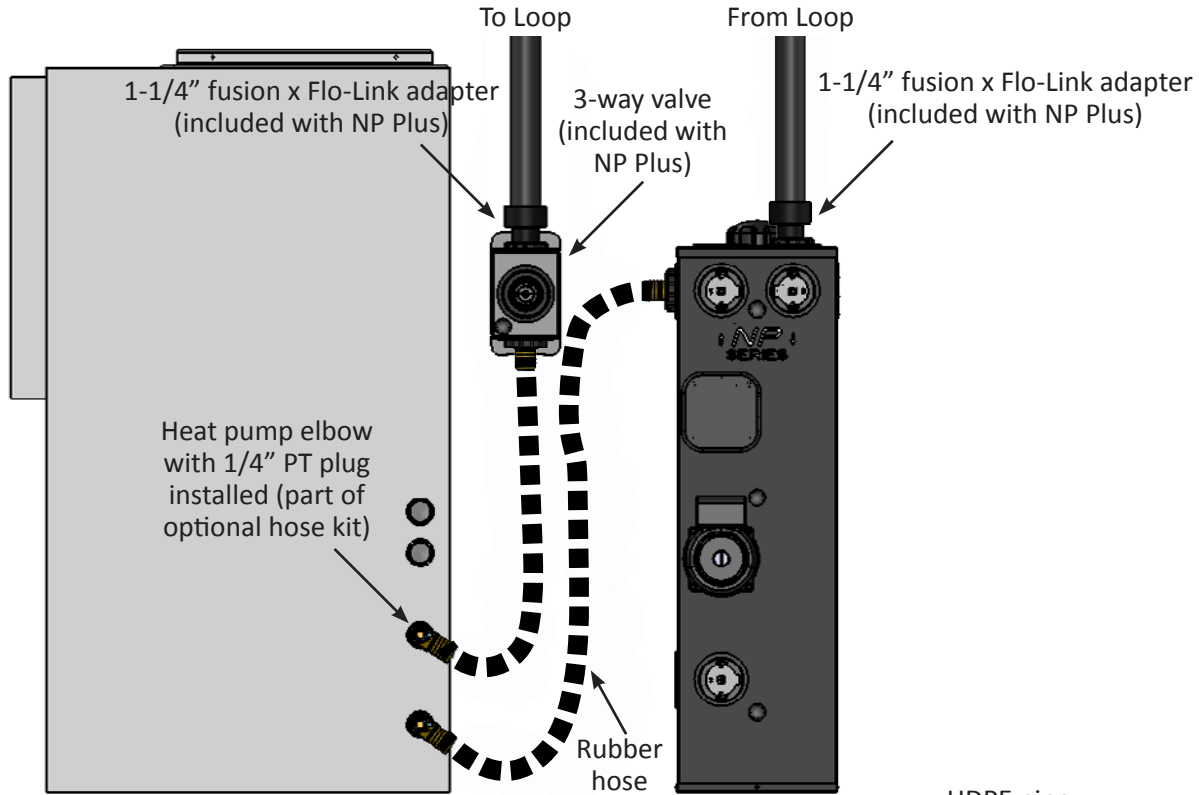

Figure 5: Outside header example of plumbing using NP Plus with hose kit for the heat pump connections and HDPE fusion adapters (included with NP Plus) for ground loop

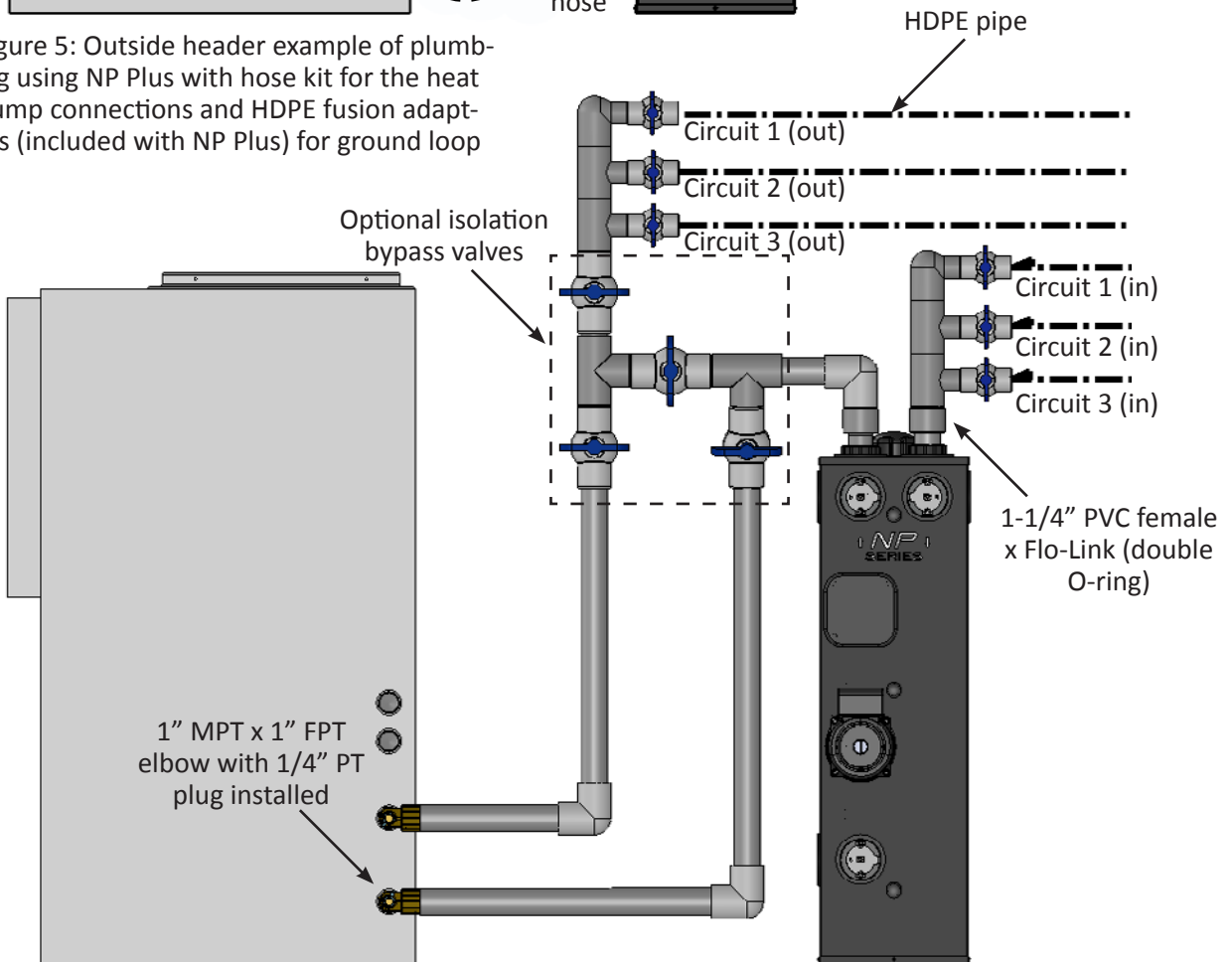

Figure 6: Inside header example of plumbing using NP Series with PVC for interior piping and inside headers



### NP Plus External 3-Way Valve Location

The NP Plus flow center ships with an external 3-way valve that may be mounted in the most convenient location for the ground loop and heat pump piping. Mounting the valve on the side of the flow center (Figure 7) or mounting on the wall (Figure 8) are the most common locations. However, the valve may also be mounted at the heat pump.



**CAUTION: IF MOUNTING EXTERNAL 3-WAY VALVE ON THE FLOW CENTER, USE ONLY THE SHEET METAL SCREWS SUPPLIED IN THE HARDWARE BAG TO AVOID PENETRATING THE TANK. THE LAG BOLTS SUPPLIED ARE FOR WALL MOUNTING ONLY.**

The external 3-way valve has two purposes, isolation and flushing/purging. With the plug seal and cap in place at the flush port, the 3-way valve may be rotated to shut off flow to the heat pump, while isolating the ground loop. The external valve is also used during the flushing and purging process to allow flushing of the heat pump heat exchanger independently of the ground loop (see Flushing and Purging section). This allows the ground loop and flow center to be installed, flushed, and filled prior to installing the heat pump and interior piping.



Figure 7: Flow center mounted 3-way valve



Figure 8: Wall mounted 3-way valve



## Flushing and Purging

### Flushing with NP Series Flow Center (Outside and Inside Headers)

NOTICE: Using a quality flush cart is the fastest and easiest way to ensure that all air and debris is removed from the ground loop. The flush cart must be able to provide a minimum fluid velocity of 2 ft/s through all piping, provide filtering, and allow power flushing. It is extremely common for construction debris, polyethylene pipe shavings, dirt, sand, rocks, etc. to enter the ground loop piping during installation. The wet rotor circulator pump(s) used during system operation require clean, debris-free fluid to function properly. A small amount of debris in the ground loop could become lodged between the pump's rotor and stator housing causing pump failure a few days to a few years after initial installation. This preventable issue is a common mode of failure for circulators. Although the NP Series flow centers do have the ability to separate air from the loop fluid, its pumps are not powerful enough to guarantee that all air and debris can be flushed from every type of loop during the initial loop installation. Geo-Flo recommends flushing all ground loops with a quality flush cart to ensure that the loop is free of air and debris when the loop installation contractor leaves the job site.

Many contractors employ non-pressurized flow centers and internal headers to flush the ground loop when a flush cart is not available. Each circuit must be installed with a ball valve to isolate all circuits to allow the flow center pump to flush one circuit at a time. Not all loops may be flushed in this manner, especially those with larger than 3/4" PE circuit piping. The directions in the section "Flushing with NP with Inside Headers" are provided to describe this practice in as thorough manner as possible using the NP Series flow center.

### Flushing with Flush Cart -- Outside Header / Using External 3-Way Valve



**CAUTION: NEVER DEAD-HEAD THE FLUSH CART PUMP INTO THE FLUID RESERVOIR OF THE NP SERIES RESERVOIR TANK. NEVER ATTEMPT TO FLUSH THROUGH THE TANK USING A FLUSH CART PUMP. OVER-PRESSURIZATION OF THE FLUID RESERVOIR COULD BE DANGEROUS AND WILL VOID THE WARRANTY.**

1. Rotate supply and return valves to bypass the tank. OFF should be in the 6-o'clock position on both valve #1 and #2 (Figure 9).

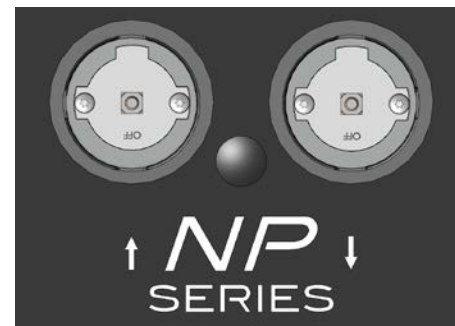

Figure 9: Valve positions for flushing with flush cart. OFF is in 6 o'clock position.

2. Remove the cap from the NP Series tank. This step is precautionary and intended to protect the flow center from accidental over-pressurization. If the operator places the valves in the incorrect orientation and starts the flush cart, the fluid from the flush cart will quickly fill and overflow the tank.
3. Attach the flush cart to the 3-way valves using Flo-Link double O-ring X 1" CAM fittings (Figure 10). Applying a small amount of lubrication to the O-rings to allow the fittings to be installed and removed with little force. The plastic nuts should be hand-tightened only.

**NOTE:** The NBR (nitrile) O-rings used in Geo-Flo valves and on Flo-Link double O-ring fittings are not sensitive to petroleum jelly or silicone based lubricants. However, other types of natural and synthetic rubber can react to petroleum and/or silicone based lubricants. For example, silicone based lubricant should not be used with silicone O-rings or seals. There is no single lubricant than is a perfect solution for every need. Therefore, care should be taken when selecting a lubricant for a particular application.

4. Flush/purge the ground loop using a high quality flush cart (see Figure 10). The external 3-way valve (included with NP Plus) allows the ground loop to be flushed independently of the heat pump. Geo-Flo provides detailed instructions on operating the flush cart manufactured by Geo-Flo.

**NOTE:** Fluid should not enter the NP Series tank during flushing. If it does, immediately stop the flush cart pump and check to be sure the valves are in the correct orientation as shown in Figure 9.



**WARNING: ONLY USE PREMIXED ANTIFREEZE IN A NON-FLAMMABLE STATE. FAILURE TO OBSERVE SAFETY PRECAUTIONS MAY RESULT IN FIRE, INJURY, OR DEATH.**

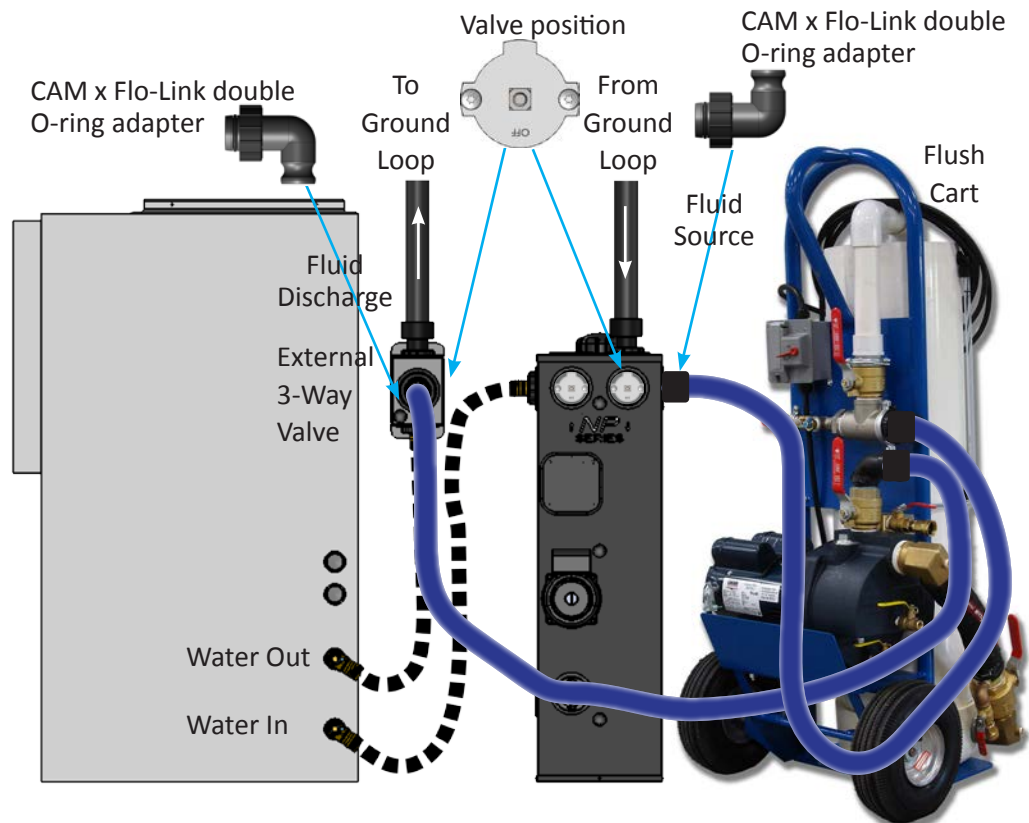

Figure 10: Connecting flush cart for ground loop flushing

5. Add antifreeze as required.
6. Turn off flush cart. DO NOT PRESSURIZE GROUND LOOP.
7. Rotate valve #2 and the external 3-way valve so that OFF position is turned towards the ground loop as shown in Figure 11.

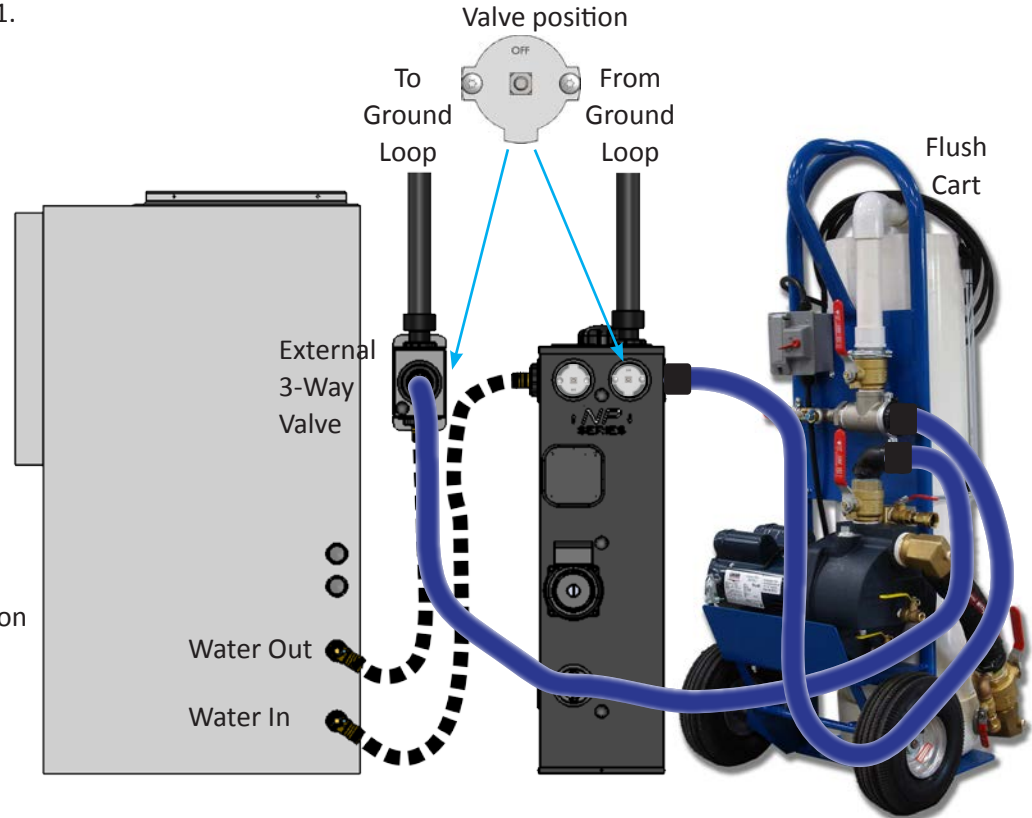

Figure 11: Valve position after ground loop has been flushed

8. Disconnect the flush cart hose from the right side of the flow center, and reconnect it to the top as shown below in Figure 12 (if heat pump piping is connected to the top, the flush cart hose would be connected to the left side).

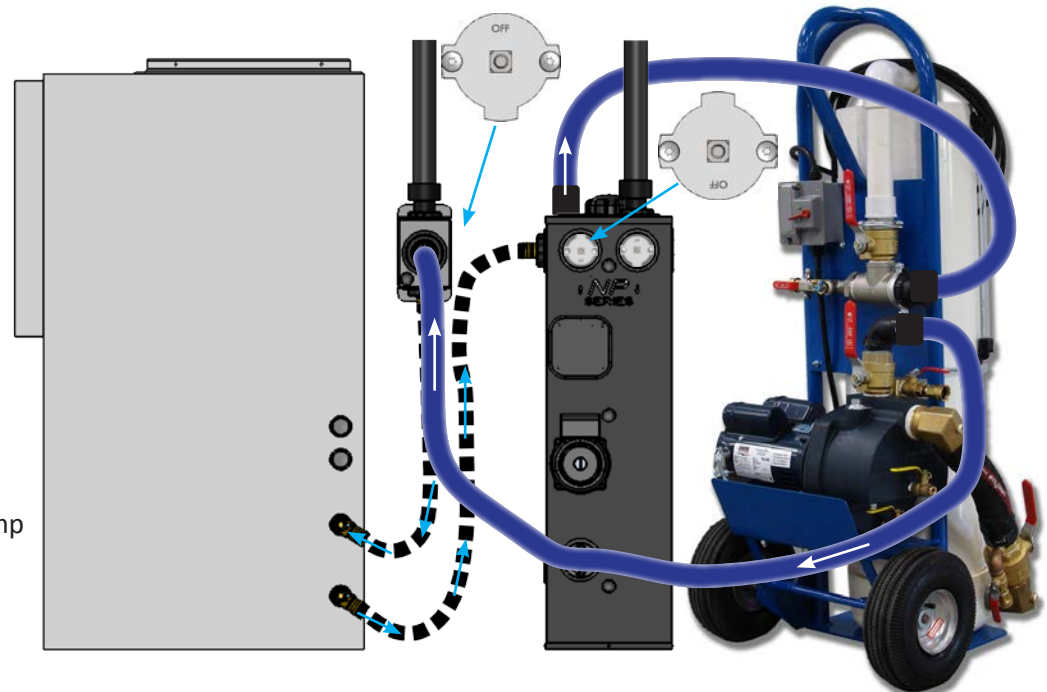

Figure 12: Connecting flush cart for heat pump flushing

9. Flush the heat pump piping with the flush cart. Turn off flush cart. DO NOT PRESSURIZE.
10. Fill the NP Series flow center reservoir with clean, debris free loop fluid. This can be the same pre-mixed fluid that remains in the flush cart after flushing and filling the loop. The tank should be filled to about 1"-2" below the bottom of the tank's neck. Figure 13 shows a cross section of the NP flow center indicating the approximate fluid level.
11. Rotate valve #1 so that OFF is toward the heat pump connection. This allows the fluid remaining in the flush cart hose to fill the pump stack and any remaining air in the stack to vent vertically.
12. Rotate valves #1 and #2 and the external 3-way valve to the operating position. OFF on the valve face will be turned toward the flush cart connection ports. At the flow center, this could be the top or side ports depending on how the unit is plumbed.
13. Disconnect the flush cart and remove the flush fittings from the flow center.

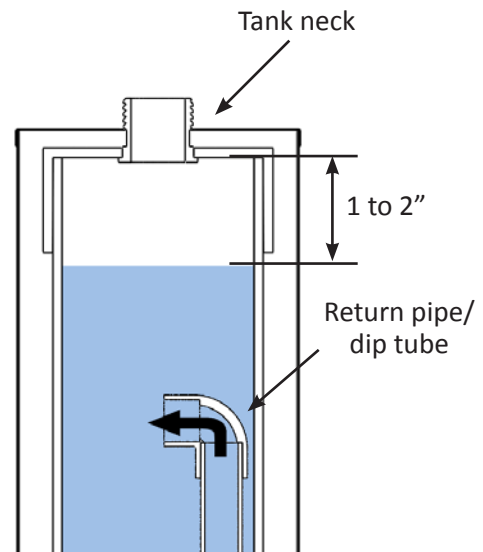

Figure 13: Fluid level of the NP tank (blue shading)

**IMPORTANT: Pull the flush fittings directly out of the valve ports. Do not rock the fittings up and down or side to side or you may crack the valve port and void the warranty.**

14. Replace the tank's cap tightening until you hear a "click" similar to an automotive gas cap.
15. Proceed to Start Up section of IOM

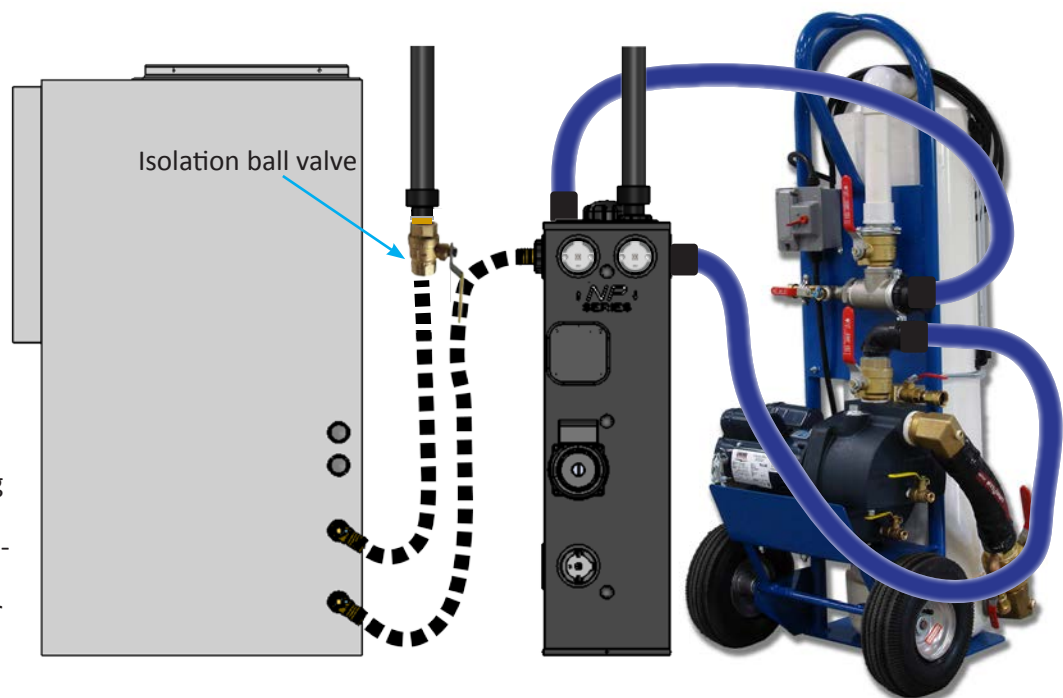

Figure 14: Connecting flush cart for ground system flushing (flushing loop and heat pump heat exchanger together)

### Flushing with Flush Cart -- Outside Header / Without External 3-Way Valve

In most cases, a residential flush cart has enough flow/head to flush a single flow center/heat pump system through the heat pump heat exchanger. Therefore, the external 3-way valve is not absolutely necessary, but is recommended for ease of installation and service. If not using the external 3-way valve, a ball valve should be used to allow isolation of the heat pump from the ground loop, as shown in Figure 14.

### Flushing with Inside Headers

NOTE: If a Geo-Gooser tool is not available, the following procedure can still be followed. However, instead of adding fluid through valve #3, fluid will be added through the top of the tank. In this case, valve #3 will remain in the 9-o'clock position throughout the process. The following instructions assume the NP Flow Center has been plumbed as shown in Figure 6. If the flow center has been plumbed with discharge and/or return pipes in the sides of the flow center, the valve positions described will vary. It is important to understand the flow through the valves before proceeding. See the General Description on page 2 of this IOM for detailed description of the valves' operation.



**WARNING: OPEN THE MAIN POWER SUPPLY DISCONNECT SWITCH AND SECURE IT IN AN OPEN POSITION PRIOR TO PERFORMING ELECTRICAL WORK. VERIFY THAT POWER HAS BEEN DISCONNECTED PRIOR TO WIRING THE PUMP(S). FAILING TO SECURE THE ELECTRICAL SUPPLY COULD RESULT IN SERIOUS INJURY OR DEATH.**

1. Wire the circulator pump(s) to a control switch to allow the pump to be powered on and off as needed during the flushing process (see Figure 18 or 19).
2. Remove the cap from the NP Series tank.
3. Cap the unused port on discharge side of the flow center with a double O-ring plug seal and cap (Figure 15). This will prevent accidental discharge through the valve during the flushing process.
4. Attach a Geo-Gooser tool with garden hose adapter to valve #3 on the flow center and a discharge hose to valve #2 as shown in Figure 15. The supply end of the hose should be connected to a clean water supply source, or to a transfer pump and pre-mixed antifreeze source.

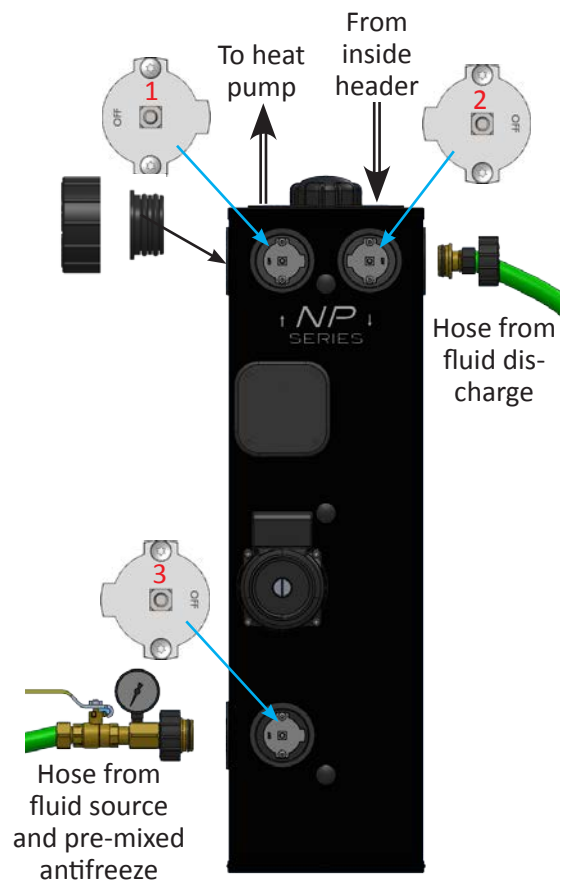

Figure 15: Flushing with inside header



5. Rotate OFF on valve #3 to the 3-o'clock position to allow the tank to be filled with fluid (Figure 15). Open the fluid supply and Gooser ball valve to allow the tank to fill. Once the tank is full, close the Gooser ball valve.
6. Open the vent screw in the center of the UP(S)26 or UP26-116 series pump motor with a large flat head screwdriver allowing a few drops of fluid to drip out. Then, retighten the vent screw. If fluid does not exit the vent screw, rotate valve #1 so OFF is at 6-o'clock and open the Gooser ball valve. This pressurizes the plumbing up to valve #1 which will help force fluid from the pump motor.

**NOTE: Step #6 is critical. Opening the vent screw and allowing fluid to drip out ensures that all trapped air has exited the pump motor. Skipping this important step could lead to premature pump failure.**

7. Close all but one of the loop circuits on the internal header.
8. Rotate valves #1 through #3 as shown in Figure 16. These valve positions will direct the fluid from the source to the loop and back through the discharge hose.
9. Open the Gooser ball valve and fill the loop circuit. Continue filling until fluid returns through the discharge hose and the loop fluid is clean and debris free, and then close the ball valve. Do not direct dirty fluid into the tank.
10. Rotate valve #1 so that OFF is in the 12-o'clock position. This prevents fluid from the loop from returning to the flow center tank (Figure 17).
11. Rotate valve #3 so that OFF is in the 3-o'clock position. This opens the valve to the tank, pump, and supply hose (Figure 17).
12. Direct the discharge hose into the top of the tank, or rotate valve #2 so that OFF is in the 3-o'clock position. Either of these actions directs the return fluid into the tank (Figure 17).

**NOTE: The pump(s) can push fluid much more quickly than can be supplied by most domestic water supply sources. Therefore, if valve #1 is completely opened it is possible for the tank to empty very quickly even if the Gooser ball valve is completely open to the source.**

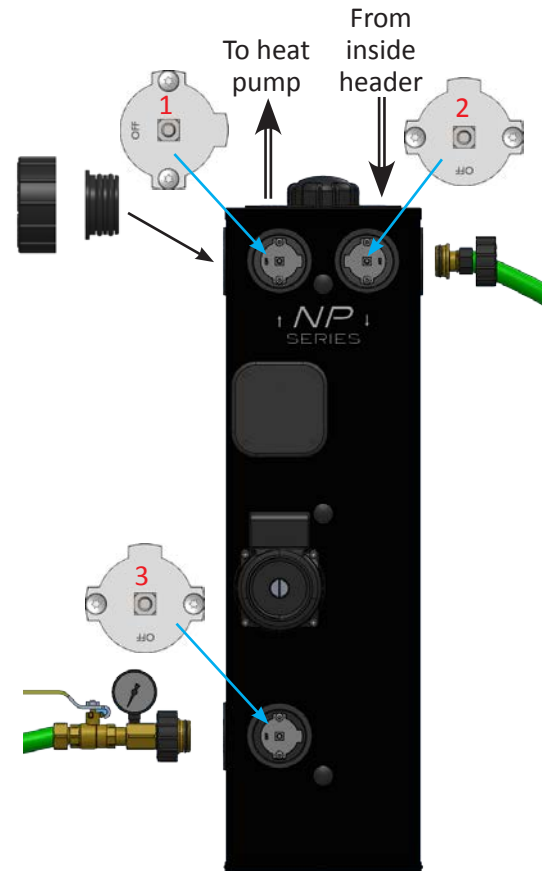

Figure 16: Filling each circuit with fluid

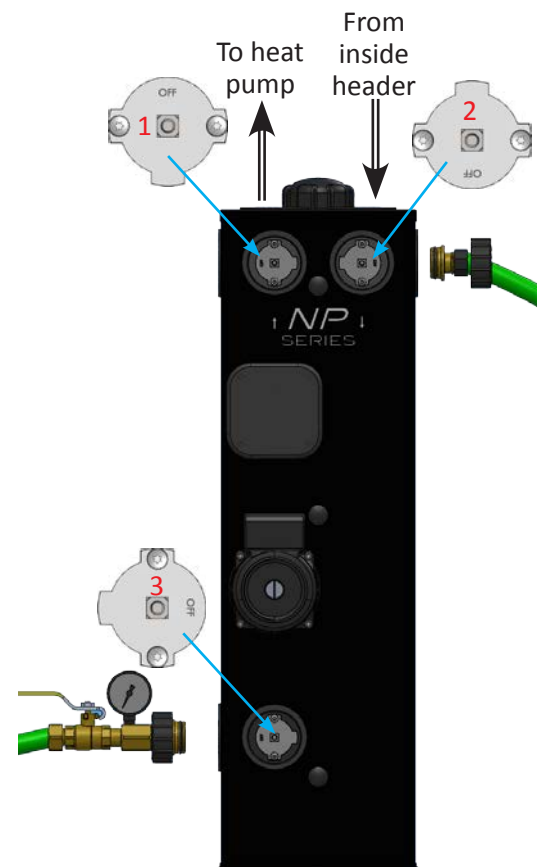

Figure 17: Purging air from the individual circuits

13. Energize the pump(s). Slowly open valve #1 by turning counter-clockwise; OFF will go from the 12 o'clock position toward the 9-o'clock position. This allows fluid from the tank to be pumped to the loop circuit. Air will be discharged into the tank as it is pushed from the loop. Monitor the fluid level in the tank and open the Gooser ball valve to supply additional fluid as needed to prevent the tank from being completely emptied.
14. When the fluid level in tank remains constant, close the Gooser ball valve and rotate valve #1 to the 9-o'clock position. This directs the full fluid flow to the loop circuit. If using 3-speed UPS26-99 pump(s), be sure they are running full-speed. If using the Magna GEO variable speed pump, disconnect the control plug to allow the pump to run at full speed.
15. Check the fluid level in the tank and add additional fluid, if necessary, by opening the Gooser valve.
16. While the pump is running, rotate valve #2 counter clockwise to the 12-o'clock position to "dead-head" the pump. If the fluid level drops more than one to two inches, air remains in the circuit and continued flushing is necessary. Rotate valve #2 back to its prior position.

NOTE: Any air in the loop is compressed when the pump(s) is running. Therefore, if air is in the loop and the pump is de-energized the air will expand pushing fluid back into the tank which can cause it to overflow. The pump should only be de-energized when the loop circuit is completely purged of air.

17. Close the individual circuit's ball valve and de-energize the pump(s).
18. Repeat steps 7 through 17 to purge each individual circuit and the heat pump.
19. After each circuit has been flushed individually, open all circuits and allow the pump(s) to run at full speed. Dead-head the pump by rotating valve #2 counterclockwise to the 12 o'clock position while monitoring the fluid level in the tank to be sure all air has been purged. If the fluid level drops more than one to two inches, air remains in the loop and purging must continue. Repeat steps 7 through 17 as needed.
20. De-energize the pump. The fluid in the tank should only rise slightly. If the tank overflows there is air in the loop and purging must continue. It may be necessary to repeat the process of isolating and purging each individual circuit.



**WARNING: ONLY USE PREMIXED ANTIFREEZE IN A NON-FLAMMABLE STATE. FAILURE TO OBSERVE SAFETY PRECAUTIONS MAY RESULT IN FIRE, INJURY, OR DEATH.**

21. Add antifreeze to the loop, if necessary. This is accomplished by adding the antifreeze to the loop while removing the same volume of water. Antifreeze is added either through the top of the tank, or via the Gooser tool with garden hose adapter. The antifreeze is pumped to the loop while water is removed through valve #2 and a discharge hose.
22. Proceed to Start Up section of this document.



### Pump High Voltage Wiring



**WARNING: OPEN THE MAIN POWER SUPPLY DISCONNECT SWITCH AND SECURE IT IN AN OPEN POSITION PRIOR TO PERFORMING ELECTRICAL WORK. VERIFY THAT POWER HAS BEEN DISCONNECTED PRIOR TO WIRING THE PUMP(S). FAILING TO SECURE THE ELECTRICAL SUPPLY COULD RESULT IN SERIOUS INJURY OR DEATH.**

Wire the circulator pump(s) to the heat pump as shown in Figure 18 (constant speed pumps) or Figure 19 (variable speed pump). Follow all electrical and local codes for wiring and fuse/breaker sizing.

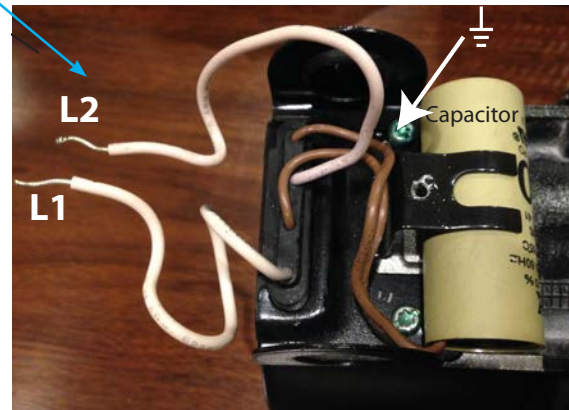
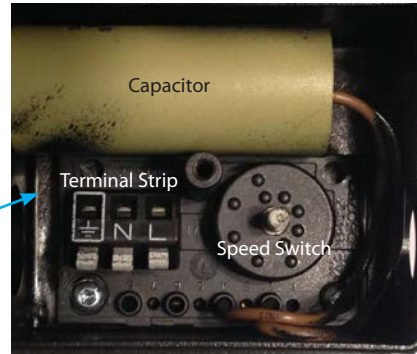
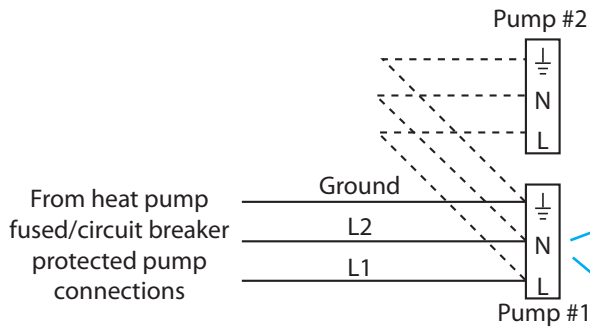
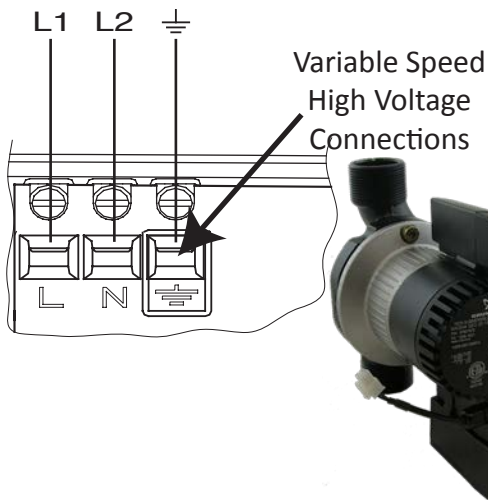

Figure 18: Pump field wiring. Top picture shows UPS26-99 control box; bottom picture shows UP26-116 control box.

From "L" side of heat pump contactor



**CAUTION: DO NOT CONNECT THE VARIABLE SPEED PUMP TO THE "T" SIDE OF THE HEAT PUMP CONTACTOR. THE VARIABLE SPEED PUMP MUST BE POWERED AT ALL TIMES. AFTER VERIFYING THAT THE HEAT PUMP BREAKER AND WIRE SIZE IS SUFFICIENT FOR BOTH THE HEAT PUMP AND THE FLOW CENTER PUMP(S), CONNECT THE VARIABLE SPEED PUMP TO THE "L" SIDE OF THE CONTACTOR.**

Remove cover to access high voltage connections

Figure 19: Pump field wiring, Magna GEO variable speed pump

## Optional Pressure Relief Piping

NP series flow centers currently ship with two different size caps on the top of the flow center. Both flow centers include pressure relief and vacuum relief. The smaller 3.3 inch cap includes pressure and vacuum relief built into the cap. The NP Plus flow centers and NP flow centers with the larger 4.5 inch cap include vacuum relief built into the cap, but pressure relief is external as shown in Figure 20. A dust cover is installed at the factory, and does not need to be removed. Under normal circumstances, the pressure relief valve does not need any external connection to a drain line since the valve will typically vent only a small amount of air to control over-pressurization. For applications where there are concerns about unusual pressure fluctuations, or there is a desire to exercise extreme caution, the valve may be plumbed to a 3/4" drain line using a 3/4" PVC coupling. Care must be exercised to avoid getting any cement inside the pressure relief valve. Apply cement only on the external surface of the valve, and not inside the female coupling to avoid having excess cement run downward into the valve.

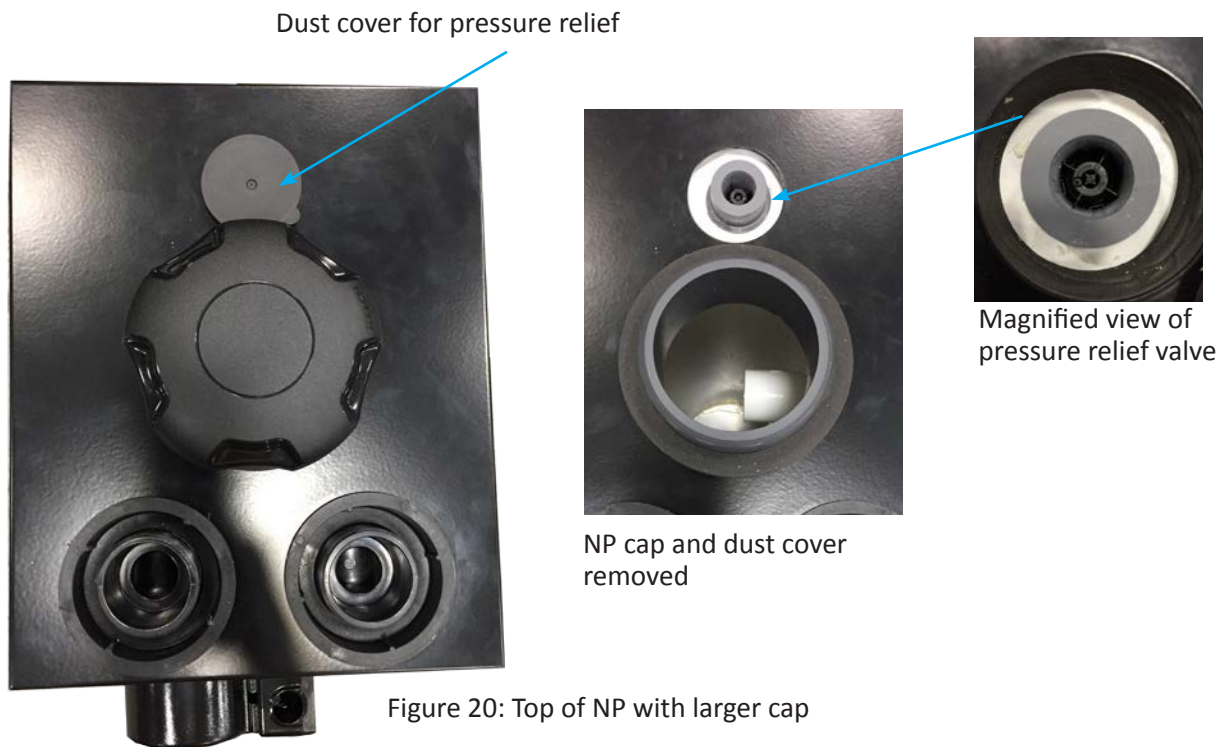

## Start-Up

1. Rotate NP Series flow center valves to the correct operating positions. The positions will depend on which ports are used for plumbing the flow center. OFF for valve #1 (top left) will be in either the 9- or 12-o'clock position, OFF for valve #2 (top right) will be in the 3- or 12-o'clock position, and OFF for valve #3 (bottom) will be in the 9-o'clock position. Consult Figure 1 for fluid flow direction. If installed, OFF for the external 3-way valve should be towards the flush port.
2. Open the vent screw in the center of the pump motor (if equipped -- not applicable for variable speed pumps) with a large flat head screwdriver allowing a few drops of fluid to drip out. Then, retighten the vent screw.

**NOTE: This step is critical for constant speed pumps (not applicable for Magna GEO variable speed pump). Opening the vent screw and allowing fluid to drip out ensures that all trapped air has exited the pump motor. Skipping this important step could lead to premature pump failure.**

3. Start flow center pump(s) and allow system to operate for several minutes. Remove tank's cap and check fluid level adding additional loop fluid, if necessary, while pump(s) are running. Fluid should be about 2" below the bottom of the tank's neck as shown in Figure 13. Replace the cap and tighten until there is an audible "click" similar to an automobile's gas cap.
4. Measure and record the flow rate using one of the methods described in the following section of this document. If using a NP1-99 or NP2-99 with three speed pumps, the flow can be adjusted by changing the pump(s) speed. The flow rate should be within the range suggested by the heat pump manufacturer.
5. Verify the performance of the heat pump per the manufacturer's literature by calculating the heat of extraction and/or rejection (HE-HR). The Geo-Flo website has a free calculator to assist in this calculation. Go to [www.geo-flo.com](http://www.geo-flo.com), select Design Calculators then HE-HR Calculator. The HE-HR should be within the range specified by the heat pump manufacturer.
6. Replace valve face covers and plug seals (Figure 21). Be sure to lubricate the O-rings on the plug seals to allow for easier removal during future service.

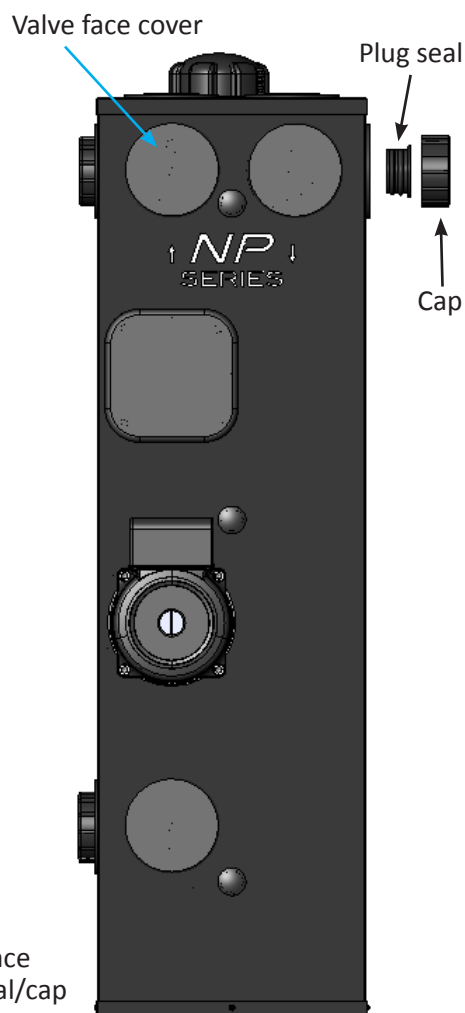

Figure 21: Valve face cover and plug seal/cap

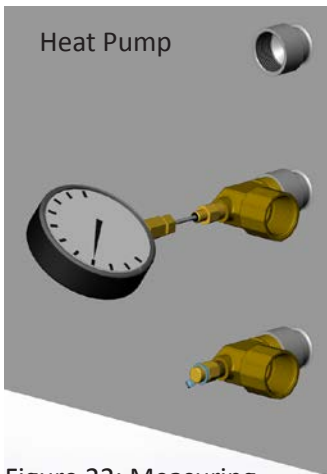

Figure 22: Measuring pressure drop

EWT °F	Flow gpm	WPD	
		PSI	FT
20	3.0	0.9	2.2
	4.5	1.8	4.2
	6.0	2.7	6.8
30	3.0	0.9	2.1
	4.5	1.7	4.0
	6.0	2.8	6.6
40	3.0	0.9	2.0
	4.5	1.7	3.9
	6.0	2.8	6.4
50	3.0	0.9	2.0
	4.5	1.6	3.8
	6.0	2.7	6.2

Figure 23: Example of heat pump manufacturer’s table of pressure drop versus flow rate

### Measuring System Flow Rate

The system flow rate can be determined using two different methods as described below.

#### Method 1: Flow rate from pressure drop

1. Measure the pressure drop across the heat pump’s heat exchanger via the PT ports located at the water connections of the unit (Figure 22). Use a single large dial face pressure gauge to allow for more precise measurement.
2. Determine the flow rate using the manufacturer’s published tables for pressure drop versus flow (Figure 23). If the pressure drop is off the manufacturer’s chart, the flow rate can be determined using a free online calculator available on Geo-Flo’s website. Go to [www.geo-flo.com](http://www.geo-flo.com), select Design Calculators then Flow Rate Calculator.

#### Method 2: Direct measurement using a Geo-Meter

1. Attach the Geo-Meter to valve #2 using a Flo-Link double O-ring x 1” CAM fitting and direct the flexible hose into the top of the tank (Figure 24).
2. Energize the pump(s).
3. Rotate valve #2 so that OFF is in the 6-o’clock position. This directs the fluid through the Geo-Meter. Be sure the Geo-Meter is vertical.
4. Read the flow rate.



Figure 24: Geo-Meter tool used for flow rate measurement

## Maintenance

There is no regularly scheduled maintenance required for the NP Series flow center. However, the fluid level in the tank should be monitored particularly during the first several days after installation or service has been performed.

### Replacing circulator pump



**WARNING: OPEN THE MAIN POWER SUPPLY DISCONNECT SWITCH AND SECURE IT IN AN OPEN POSITION PRIOR TO PERFORMING ELECTRICAL WORK. VERIFY THAT POWER HAS BEEN DISCONNECTED PRIOR TO WIRING THE PUMP(S). FAILING TO SECURE THE ELECTRICAL SUPPLY COULD RESULT IN SERIOUS INJURY OR DEATH.**

1. Determine whether the circulator pump needs to be replaced. The pump motor should only be replaced after successfully troubleshooting the system and determining that the pump is not functioning. See Troubleshooting section of this document for more information.
2. Rotate OFF on valve #1 to isolate the flow center from the heat pump. This will either be the 9- or 12-o'clock position depending on how the flow center was installed. Remove the cap and plug seal on valve #1.
3. Remove the cap and plug seal on valve #3. Rotate OFF on valve #3 to the 6-o'clock position and capture the fluid that exits valve #3 in a pan. Retain this fluid to add back to the tank after service is complete (Figure 25).
4. Verify that power has been disconnected from the circulator pump(s) using a multimeter.
5. Disconnect wiring from pump.
6. Remove screws holding pump motor to pump housing (volute), and remove the pump motor.
7. Inspect the pump motor and volute for signs that indicate the mode of failure. For example, if debris is present in the pump or volute the ground loop should be re-flushed with a quality flush cart equipped with a filter.
8. Clean the pump seat on the pump housing (volute) with a cloth to remove any debris so that the gasket on the pump will seal properly. Install the new pump motor and reconnect wiring.
9. Replace the plug seal and cap on valve #3. Rotate valve #3 to

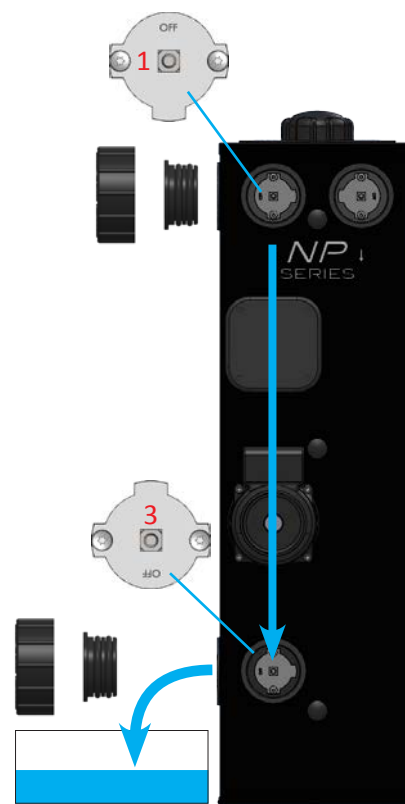

Figure 25: Catching fluid in pump stack when replacing pump motor

operating position (OFF in 9-o'clock position). Fluid from the tank will fill the valve/pump stack.

10. Replace the loop fluid that was removed from the system in Step 3. Fill the tank as needed.
11. Rotate valve #1 to the operating position and replace the plug seal and cap on this valve.
12. Open the vent screw in the center of the pump motor just installed with a large flat head screwdriver allowing a few drops of fluid to drip out. Then, retighten the vent screw.

NOTE: This step is critical. Opening the vent screw and allowing fluid to drip out ensures that all trapped air has exited the pump motor. Skipping this important step could lead to premature pump failure.

13. Energize the pump.
14. Verify system performance by checking the flow rate and temperature differential, and comparing the values to the heat pump manufacturer's published data. If installing a UPS26-99, be sure to set the pump speed that provides a flow rate within the manufacturer's recommend range.
15. Remove the tank's cap and check the fluid level. Fluid should be about 2" below the bottom of the tank's neck as shown in Figure 13. Replace the cap and tighten until there is an audible "click" similar to an automobile's gas cap.
16. Replace valve face covers and plug seals as shown in Figure 21. Be sure to lubricate the O-rings on the plug seals to allow for easier removal during future service.

### Converting NP1 to NP2 or NPV1 to NPV2

Follow procedure for Replacing Circulator Pump except remove the blank plate instead of the pump motor. Be sure to remove the gasket (Figure 26).

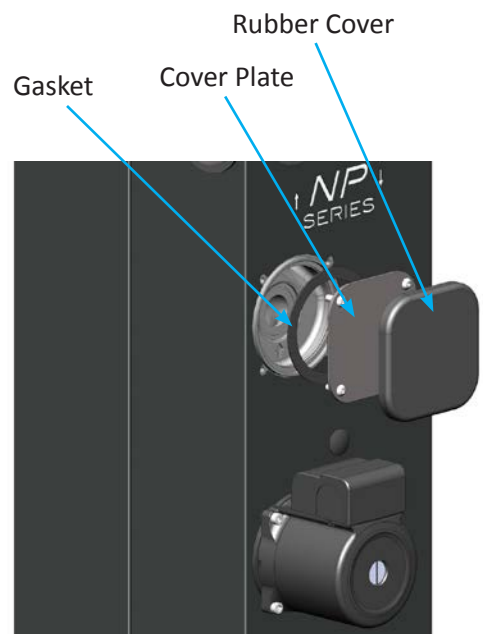

Figure 26: Removing cover plate

**Checking anti-freeze/freeze protection level**

The loop fluid may contain antifreeze at concentration high enough to achieve a freeze protection level that is generally 10 degrees lower than the lowest expected entering fluid temperature (EWT) to the heat pump. Antifreeze will be used when the loop fluid entering the heat pump (EWT) is expected to drop below 40 degrees F. The freeze protection level depends on the type and concentration of antifreeze.

Loop fluid can be removed from the NP flow center through one of the three way valves, or through the top of the tank. The specific gravity of the fluid can then be measured with an appropriate specific gravity hydrometer. The specific gravity is used to determine the percentage concentration of antifreeze which is then used to determine the freeze protection level. The Residential Pressure Drop calculator available at [www.geo-flo.com](http://www.geo-flo.com) provides information on percent antifreeze, freeze protection level, and specific gravity for ethanol, methanol, and propylene glycol.

**Emptying the tank**

Valves #1 and #2 should be turned to isolate the NP flow center from the ground loop and heat pump. The tank can be emptied by rotating valve #3 so that OFF is at the 3 o'clock position. A discharge hose can be connected to valve #3 to direct the fluid to a drain or catch basin. Note that the NP Series flow center will hold approximately 3-1/2 gallons of fluid.



## Troubleshooting

Problem	Possible Cause	Solution
Water leaks out Cap	Tank over-pressurized	Remove loop fluid
	Cap not sealing	Remove cap; clean reservoir neck and cap gasket; replace cap
		Remove cap; apply lubricant to cap gasket; replace cap
Water leaks out of tank when cap is removed and pump is not energized	Air in loop	Flush system to remove air
	System pressurized	Replace cap quickly; not a problem
Water leaks out valve face	Debris in valve	Rotate valve 360 degrees to dislodge debris
		Remove valve spool; clean valve body and spool; replace O-ring(s) on valve spool if necessary
	Side loading valve spool when rotating with 3/8" drive tool	Rotate valve spool so that no side load is placed on spool
Water drips around O-ring adapter/fittings	Incorrect fitting used (i.e. threaded fitting instead of Flo-Link double O-ring fitting)	Replace incorrect fittings
	Condensation	Insulate piping
	O-ring seal failure	Remove fitting; clean valve port and fittings; replace O-rings if necessary
	Pipe misalignment; side-loading O-rings	Remove fittings; check O-rings and replace if necessary; align piping
Noise in reservoir tank	Air in loop system passing into reservoir	Not a problem. Monitor fluid level; add fluid if necessary
	Low water level in reservoir	Add loop fluid
Low water level in reservoir	Air from loop system deposited into reservoir	Not a problem; add loop fluid
	Pipe expansion	Not a problem; add loop fluid if necessary
	Leak in interior piping	Locate and repair leak
	Leak in ground loop system	Locate and repair leak
No flow to/from tank	Valve(s) in wrong position	Rotate valve(s) to operating position
Air not separating from fluid	Valve(s) in wrong position	Rotate valve(s) to operating position
Pump not operating	No power at pump	Ensure proper power/voltage at pump motor
		Ensure heat pump contacts are operating
		Reset fuse/break in heat pump
	Power at pump but not operating	Remove vent screw and rotate shaft with a small screwdriver. Replace vent screw and re-energize pump. Replace pump power head

# Manual Updates Table

Date	Description of Changes	Pages
03OCT2016	Formatting changes	All
	Added NP Plus flow center information	Various
	Updated Figure 5 to show NP Plus piping	5
	Added section on NP Plus external 3-way valve mounting	6
	Updated flushing section to show external 3-way valve	7
	Added pump wiring	14
	Added section on optional pressure relief piping	15
17APR2013	Updated figure 1 for clarity	1
25JAN2013	First published	All





## Installation, Operating, and Maintenance Manual

NP Series Non-Pressurized Flow Centers

[www.geo-flo.com](http://www.geo-flo.com)

### Members of ...



**Geo-Flo Products Corporation**  
905 Williams Park Drive  
Bedford, Indiana 47421, U.S.A.

**Main Number: 812-275-8513**  
**Toll Free: 800-784-8069**  
**Fax: 888-477-8829**

Geo-Flo Products Corporation is continually working to improve its products. As a result, the design and specifications of products in this catalog may change without notice and may not be as described herein. For the most up-to-date information, please visit our website, or contact our customer service department at [jmoan@geo-flo.com](mailto:jmoan@geo-flo.com). Statements and other information contained in this document are not express warranties and do not form the basis of any bargain between the parties, but are merely Geo-Flo's opinion or commendation of its products.



Part # 3761